



WELCOME
to the
IEEE/PES Switchgear Committee
Fall 2015 Meeting
San Diego, CA, USA

Starts at
7:25am



Topics of Discussion

- Meeting Specific Items
- Where Do We Fit In With IEEE
 - Scope
 - Officers
 - Organization
 - Activities
 - Subcommittee Organization
- Frequently Asked Questions
- Standards Process



Safety Minute

- Be sure to know the emergency exit for each room that you enter, including your hotel room.
- Stay hydrated if out in the heat.
- Test the GFCI in your rooms.

Property Map



You Are Here

Room Locations

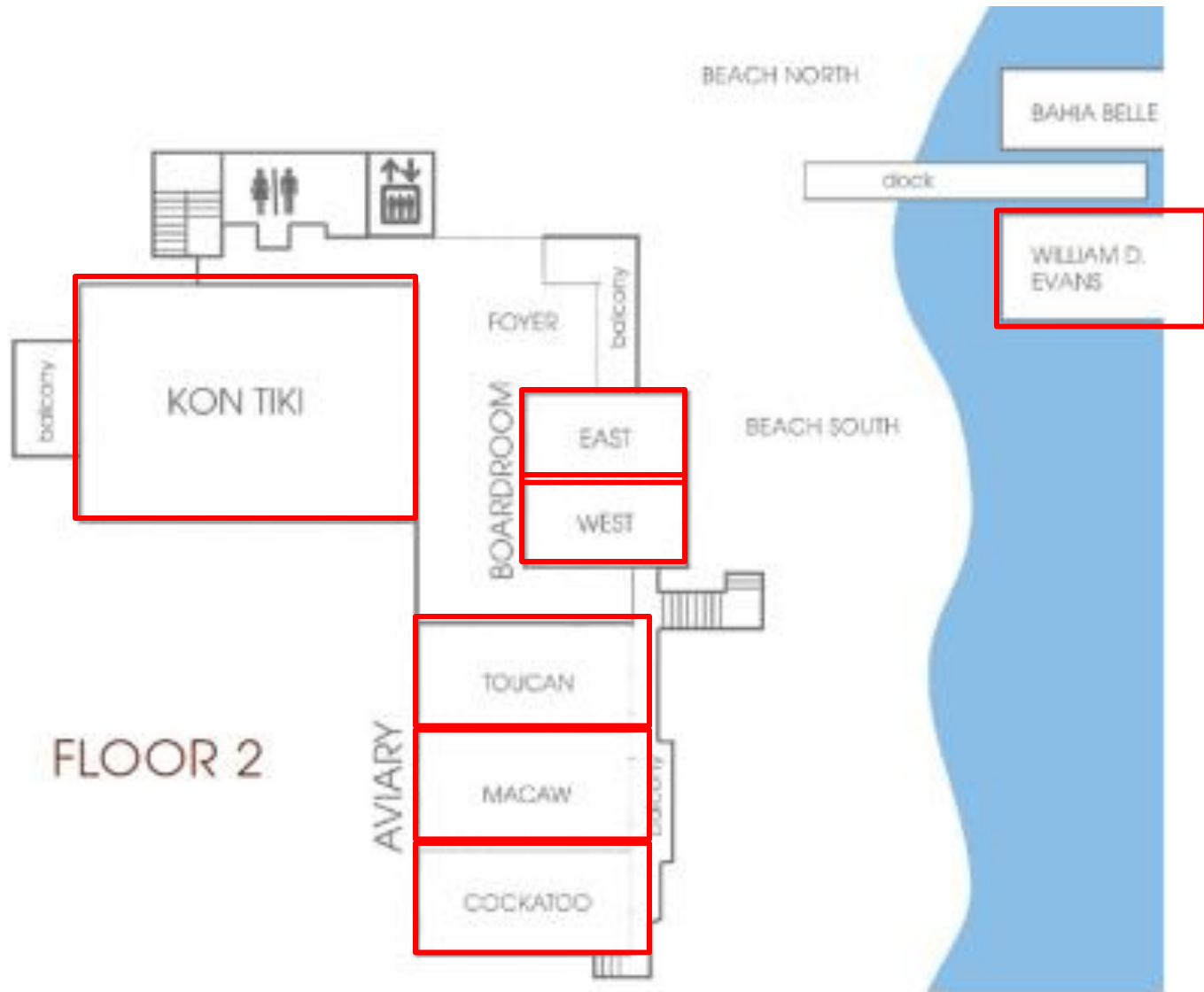

Room Locations

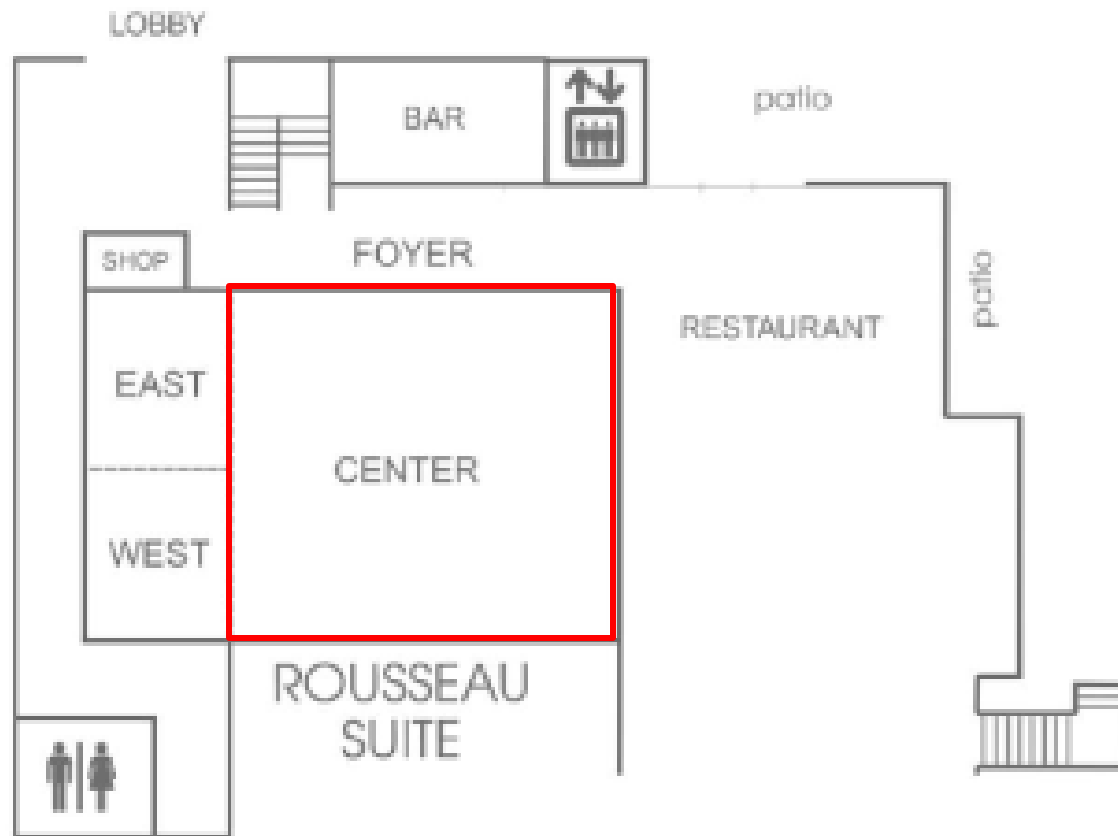

FLOOR 1



Wireless Internet Access in Meeting Rooms

- Connect to
“Catamaran_Conference”

- PASSWORD: data5

Schedule App

- Download a free app including:
 - Meeting schedule (active updates)
 - Maps for meeting rooms
 - List of supporters
 - Attendees
 - Personalized schedule with reminders
- Go to the App Store on your smart device.
- Search and download “Guidebook”
- Search for “IEEE PES Switchgear Fall 2015”

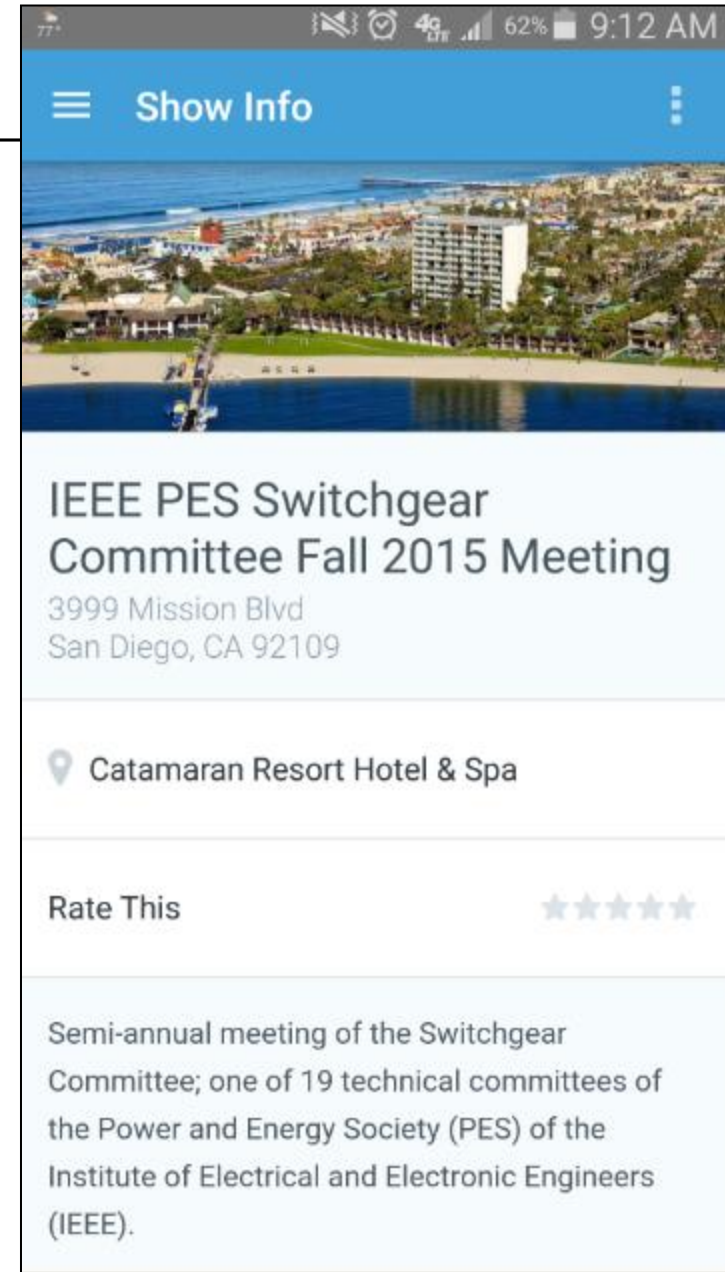



Schedule Changes

- Any reported schedule changes will be posted on the bulletin board at registration
- Also reflected in the Guidebook App.

Companion Breakfasts

- Marquesas Suite 308
(Mon, Tues, Weds, Thurs)

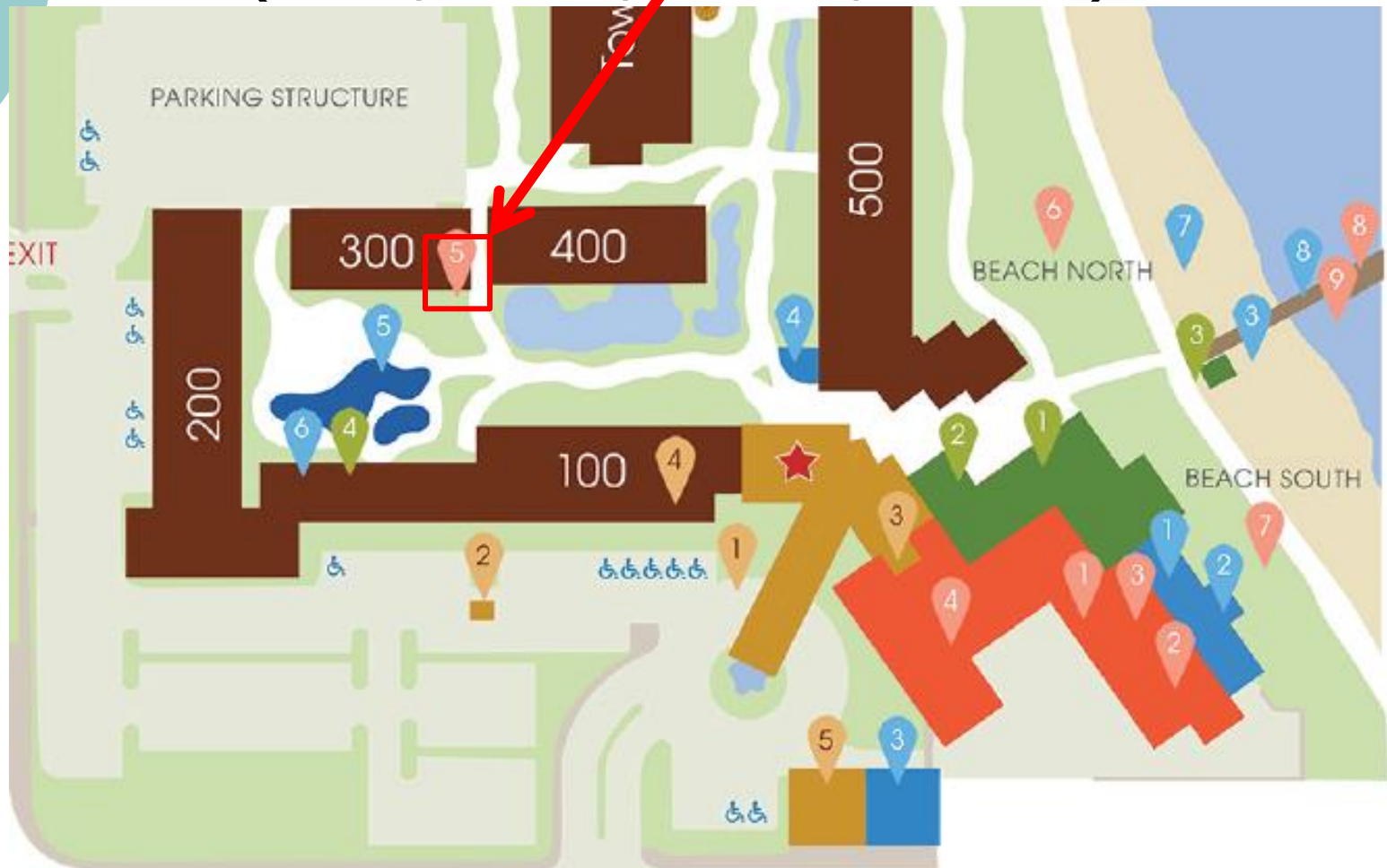



Tuesday Breakfast Presentation

- IEEE-SA Balloting & Comment Resolution Q&A
 - Erin Spiewak (IEEE-SA)
- Kon Tiki Ballroom
- Registration is NOT required.



Tuesday Luncheon Presentation

- An Engineer at Sea (“or how I learned to love semi-retirement by sailing to exotic places.”)
 - John Leach
- Kon Tiki Ballroom
- Registration is required.

Wednesday Evening Social

- Dinner & Cruise
- William D. Evans Sternwheeler
 - start boarding at 6:15pm
 - on dock at rear of hotel
 - 6:30PM to 9PM
- Registration is required.





Thursday Technical Presentation

- Electromagnetic Field Surveys of the home and office space
 - Nenad Uzelac
- Kon Tiki Ballroom
- Registration is NOT required.
- Box lunches only for those that have pre-purchased them.
 - Check your AMS (123Signup.com) registration if unsure.



Future Meetings – Confirmed

- Spring 2016
 - Apr 25-28, Sonesta Resort
 - Hilton Head, SC, USA
- Fall 2016
 - Oct 9-14, Sheraton Station Square
 - Pittsburgh, PA, USA
- Spring 2017
 - Apr 23-28, Hilton Charlotte University Place,
 - Charlotte, NC
- Fall 2017
 - Oct 8-13, Marriott Portland Sable Oaks
 - Portland, ME
- Spring 2018
 - Apr 22-27, Disney's Contemporary Resort
 - Lake Buena Vista, FL

Supporting Companies – Financial Contribution

- ABB
- Alstom
- Cleaveland Price
- DNV-GL (KEMA)
- Eaton
- G&W
- Hitachi
- MEPPI
- NEMA
- Pascor Atlantic
- Powell
- S&C
- Schneider Electric
- Siemens
- Southern States

**Thank
You!**

Supporting Companies – Projectors

- ABB
- Alstom
- Bonneville Power Administration
- Eaton
- Hubbell
- Incon
- Powell Industries
- Schneider Electric
- Siemens
- Southern Company

**Thank
You!**



Where Do We Fit In With IEEE?

Where Do We Fit In With IEEE?

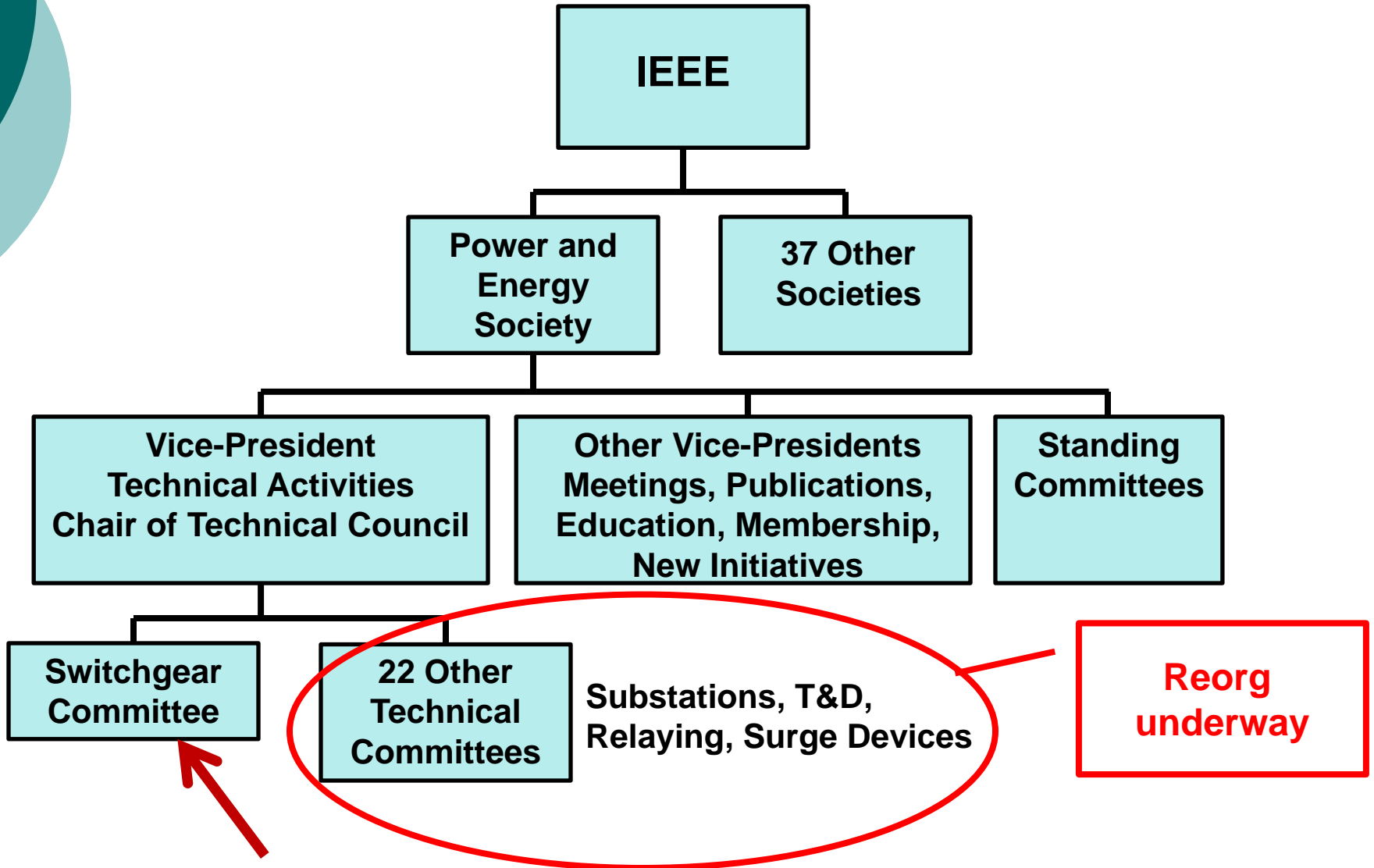



IEEE Membership

| | | |
|-------------------------------------|-----|---------|
| ○ Total IEEE membership | | 376,074 |
| ● US | 48% | 180,357 |
| ● outside the US | 52% | 195,717 |
| ○ Power & Energy Society membership | | 31,817 |
| ○ IEEE-SA Standards Association | | 6,207 |
| ○ Switchgear Committee Membership | | 77 |
| ○ Attendance (approx) | | |
| ● Spring 2015 (St Pete Beach) | | 252 |
| ● Fall 2015 (San Diego) | | 225 |

IEEE Organization

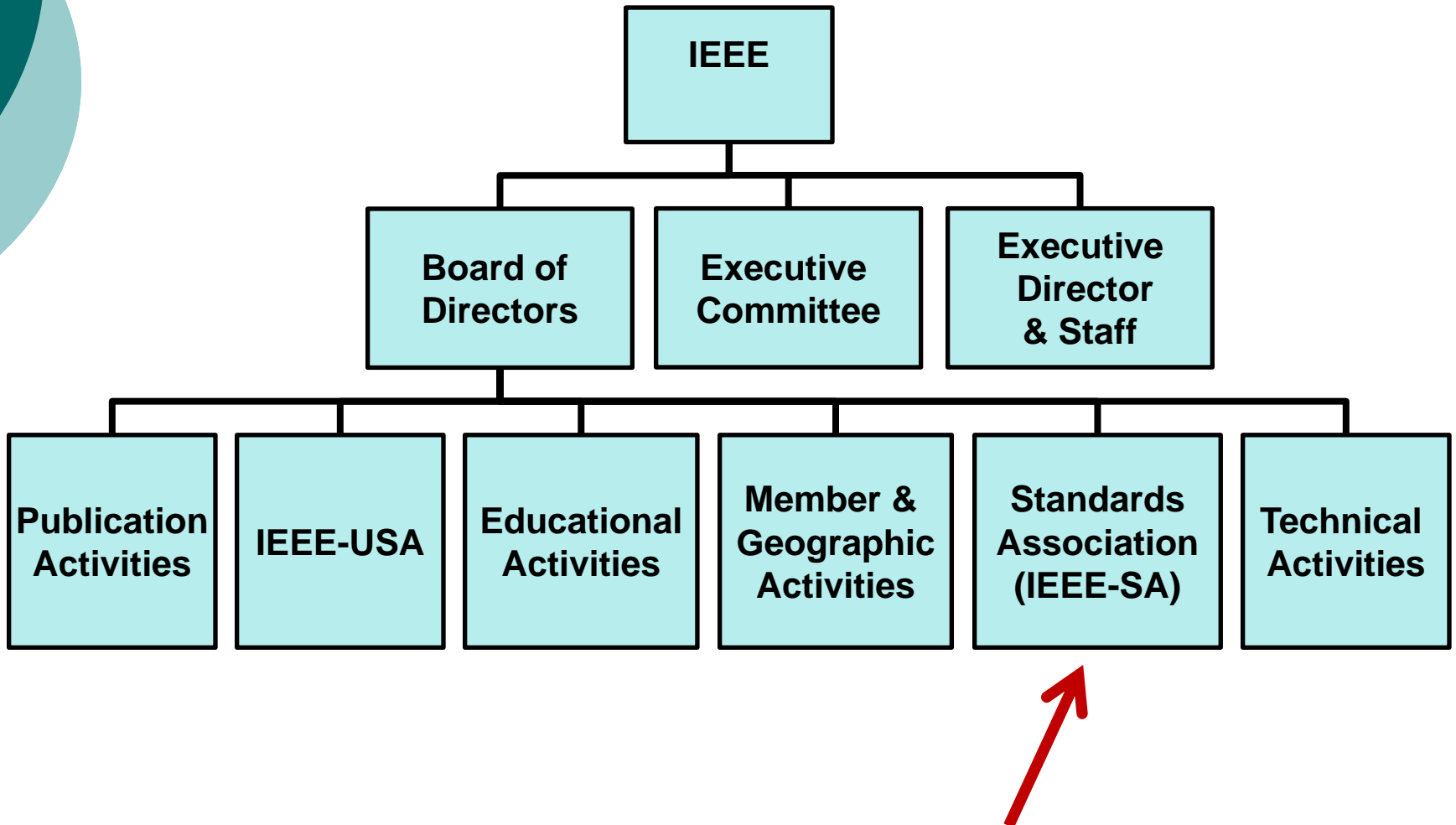

Organization – IEEE SA

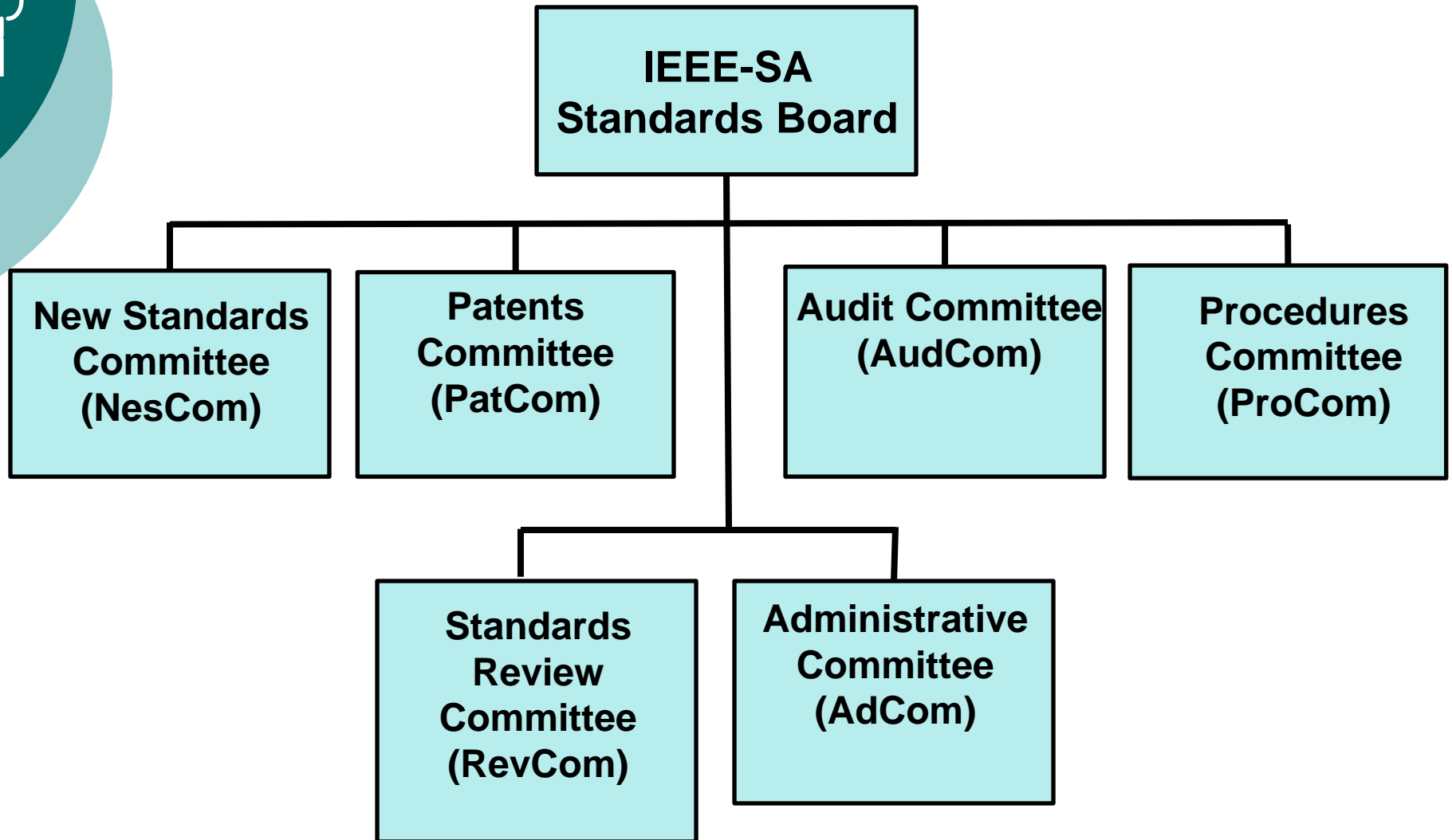



Switchgear Committee Scope

Treatment of matters in which the dominant factors are the **design**, **construction** and **operation** of **devices** or **assembled gear** to establish (**make**), **interrupt**, or **change connections** in **any electric circuit** under **normal or abnormal conditions**, including the following:



Switchgear Committee Scope

- Automatic reclosers and sectionalizers
- Current limiting devices
- Fuses and cutouts
- Gas-Insulated Switchgear (GIS)
- Insulation, insulators and hardware for switchgear
- Metal-enclosed buses and all buses included in switchgear assemblies
- Power circuit breakers
- Switches, including pad-mounted switches
- Switchgear assemblies
- Switchgear devices



Activities

- Create & Maintain IEEE Switchgear Standards
 - Including Standards, Guides, and Recommended Practices
- Prepare and Review Technical Papers
- Organize Technical Sessions
- Recognize Contributions of Members
- Further the Art of Power Engineering

Switchgear Committee Officers

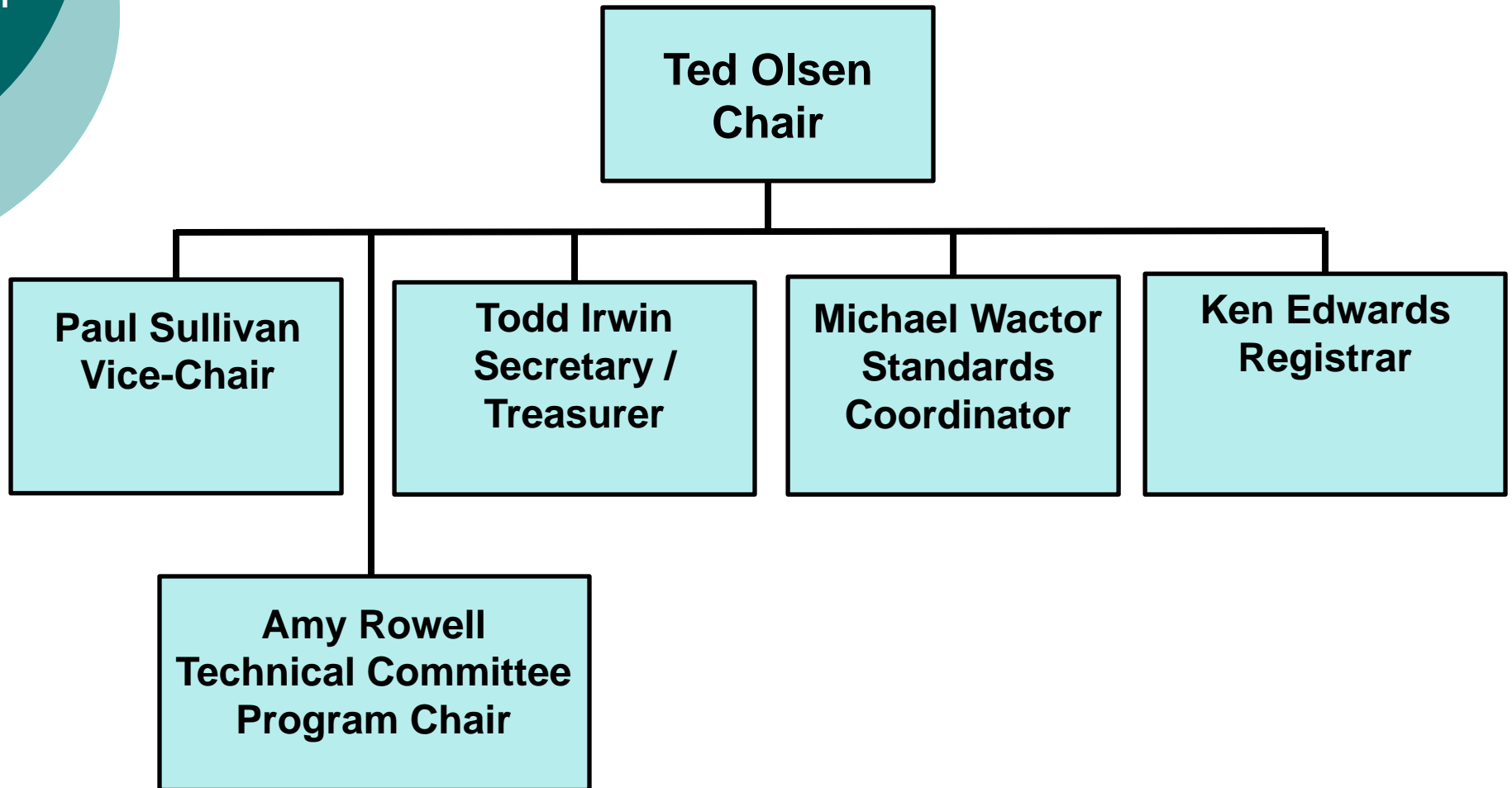

Organization – Switchgear Committee

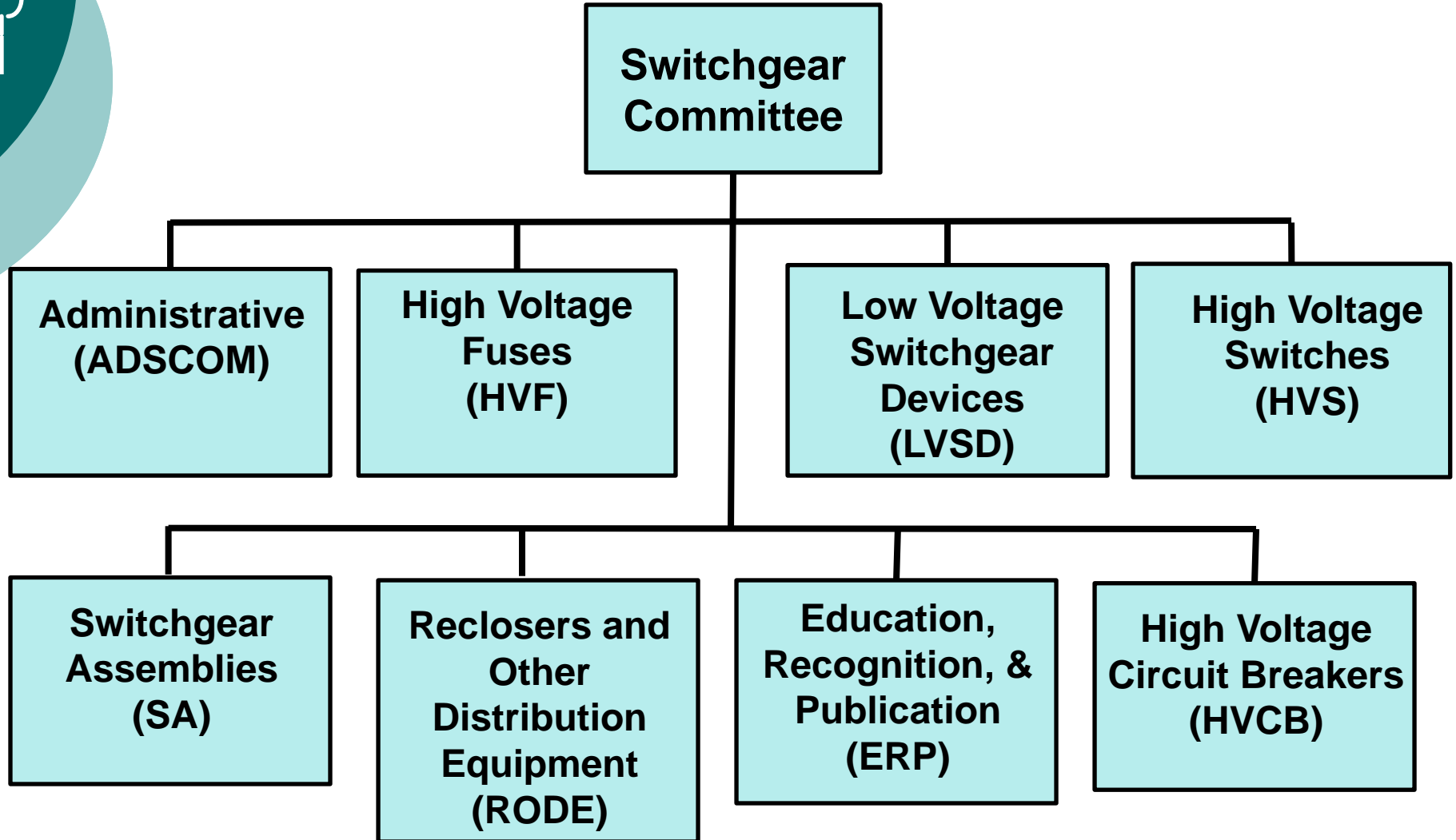

Organization – Switchgear Committee

○ Switchgear Committee

- Administrative (ADSCOM)– Paul Sullivan
- Education, Recognition, and Publication (ERP) – John Webb
- High Voltage Circuit Breakers (HVCB) – Mauricio Aristizabal
- High Voltage Fuses (HVF) – John Leach
- High Voltage Switches (HVS) – Carl Reigart
- Low Voltage Switchgear Devices (LVSD) – Allan Morse
- Reclosers & Other Distribution Equipment (RODE)– Nenad Uzelac
- Switchgear Assemblies (SA) – Doug Edwards
- Standards Coordinator – Michael Wactor
- Technical Committee Program Chair (TCPC) – Amy Rowell

Organization – Switchgear Committee

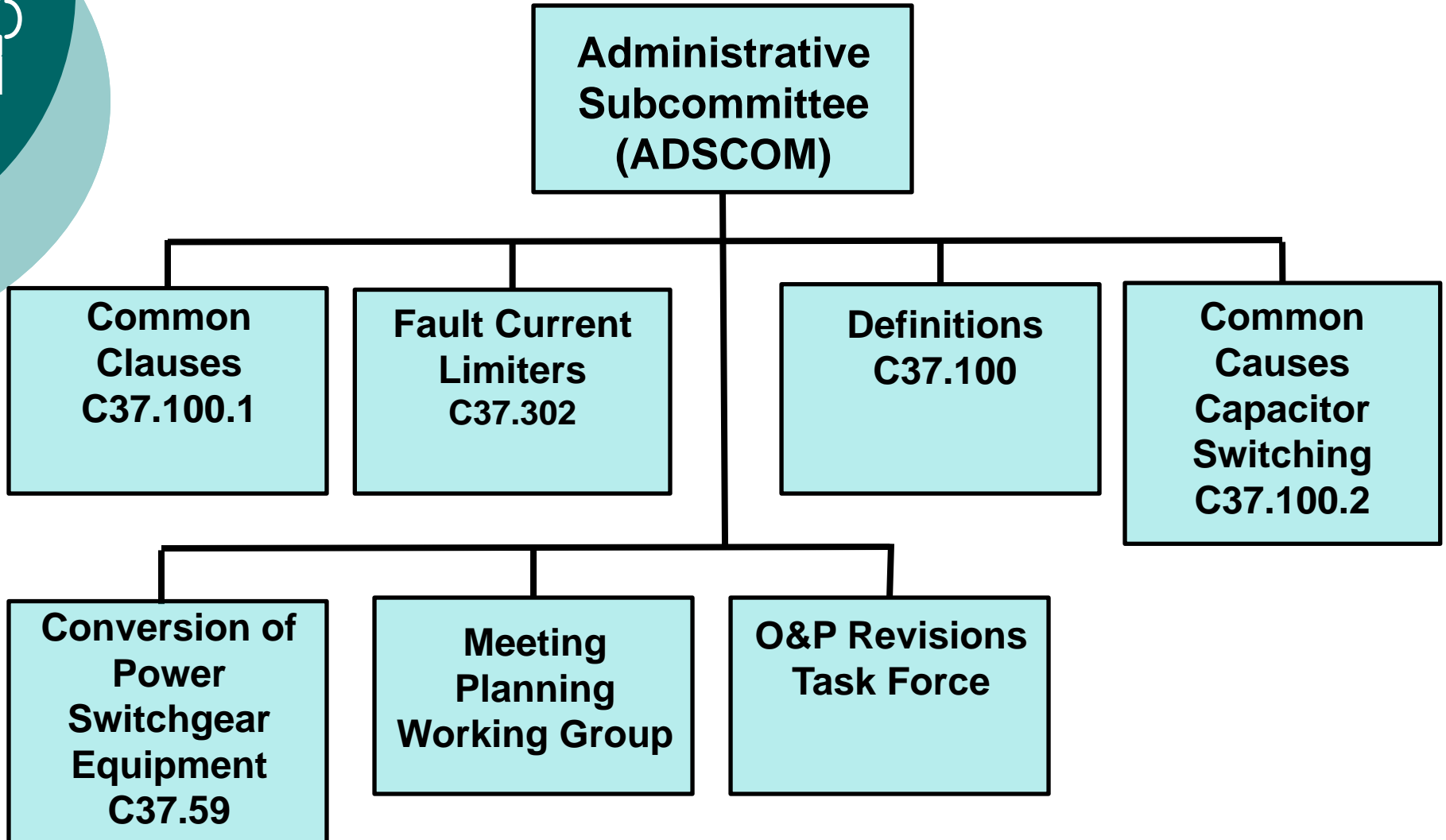

Organization – Switchgear Committee

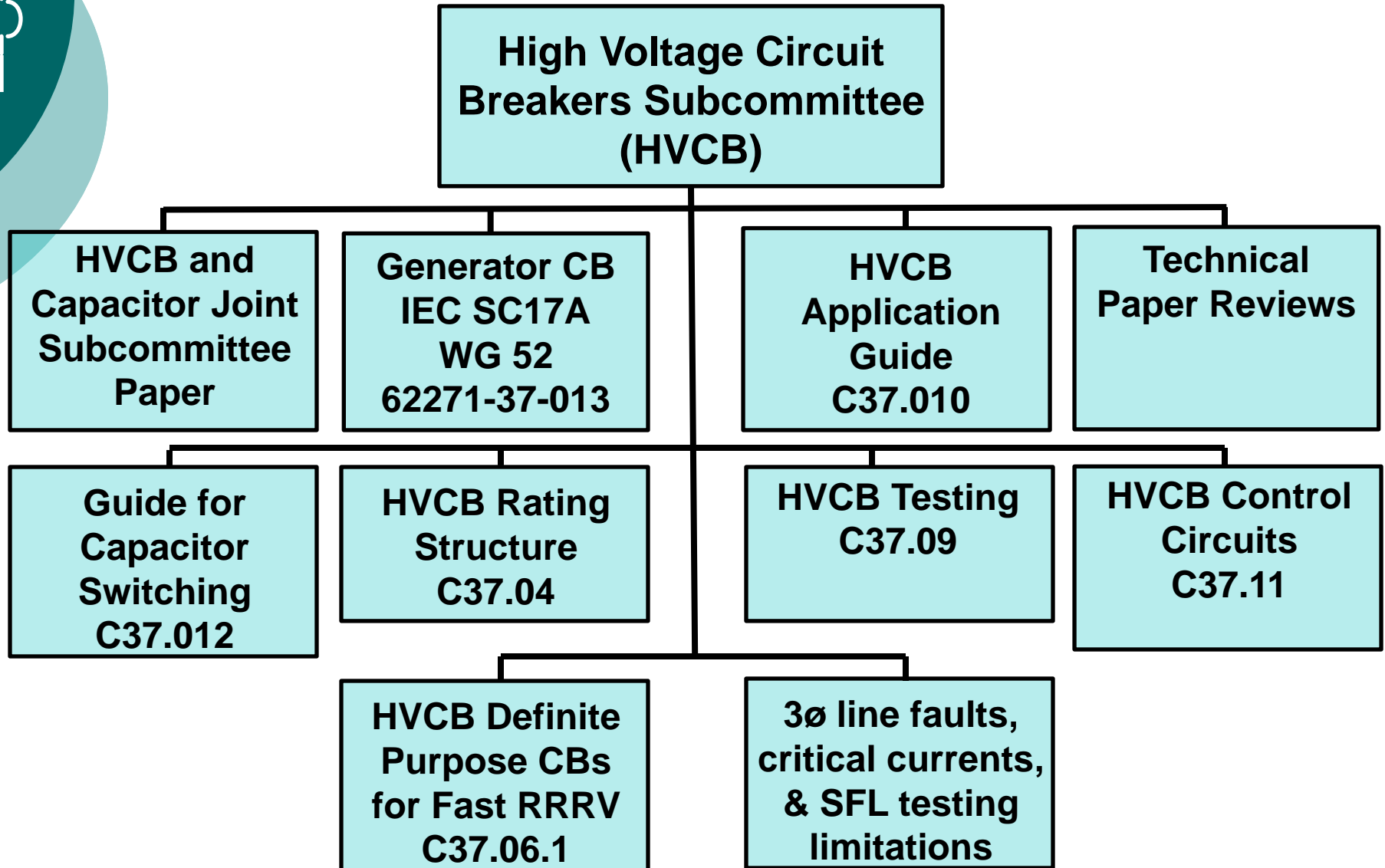

Organization – Switchgear Committee

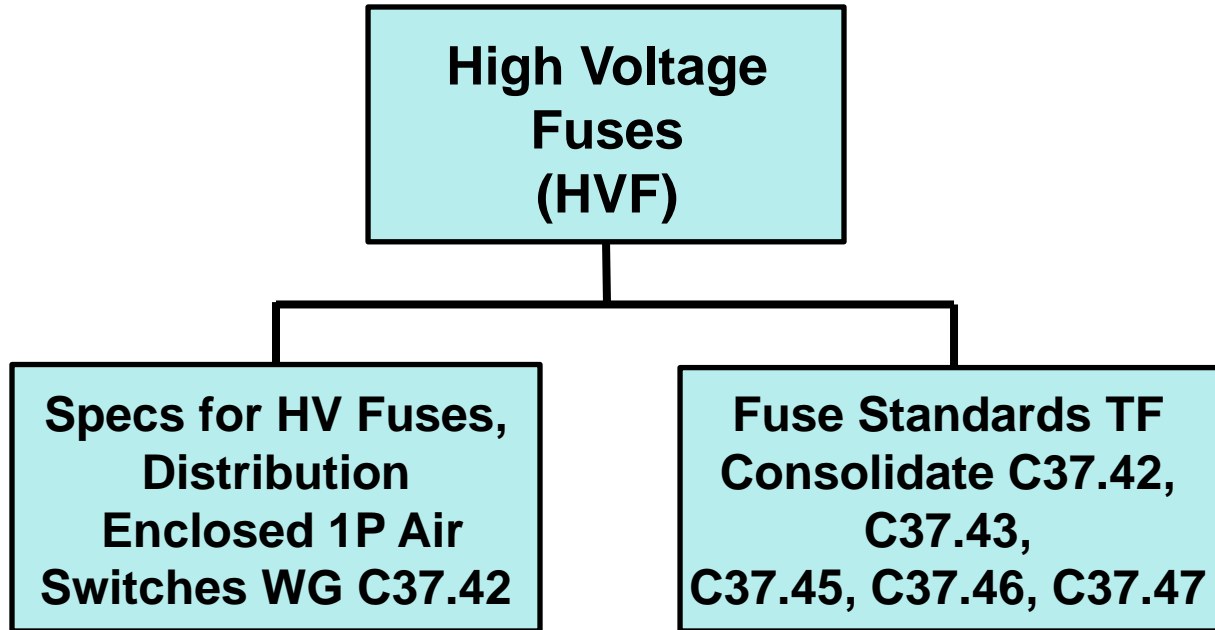

Organization – Switchgear Committee

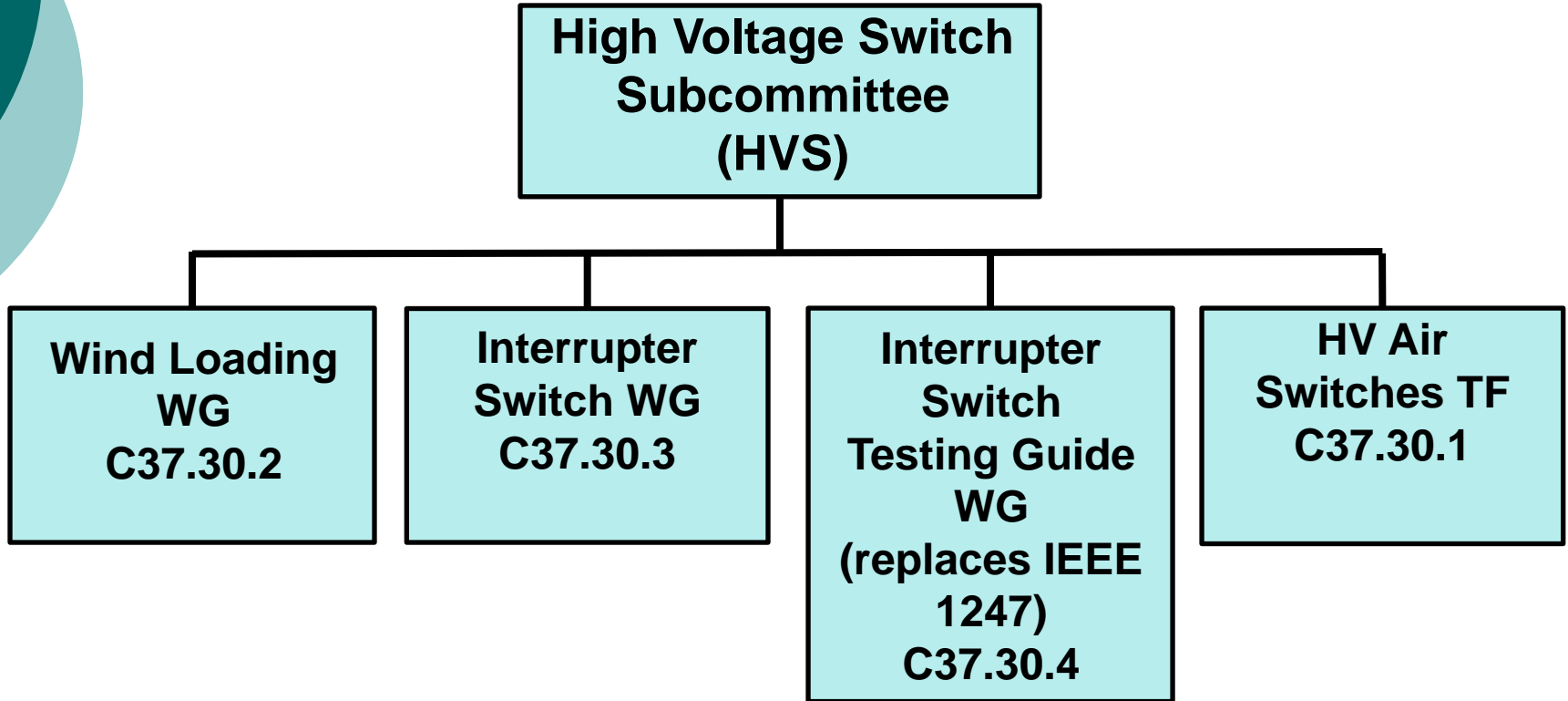

Organization – Switchgear Committee

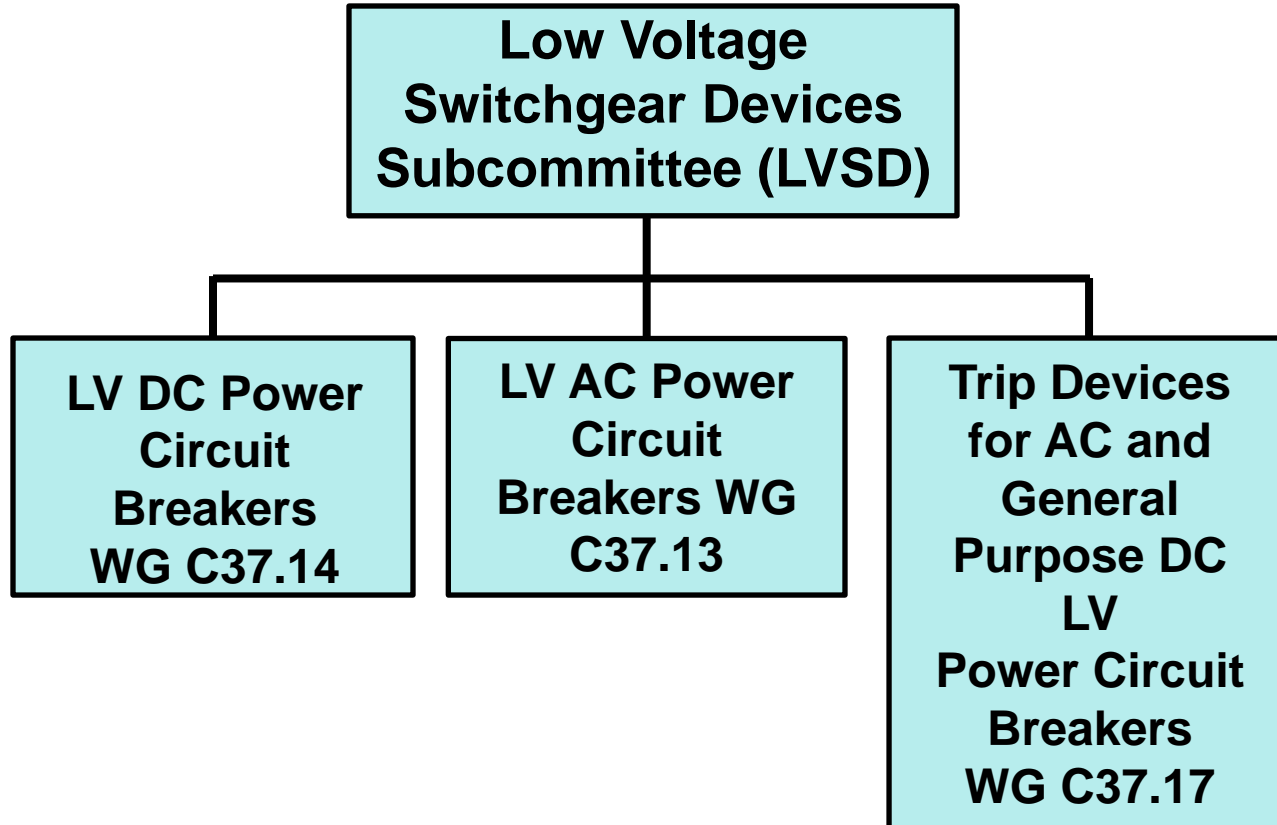

Organization – Switchgear Committee

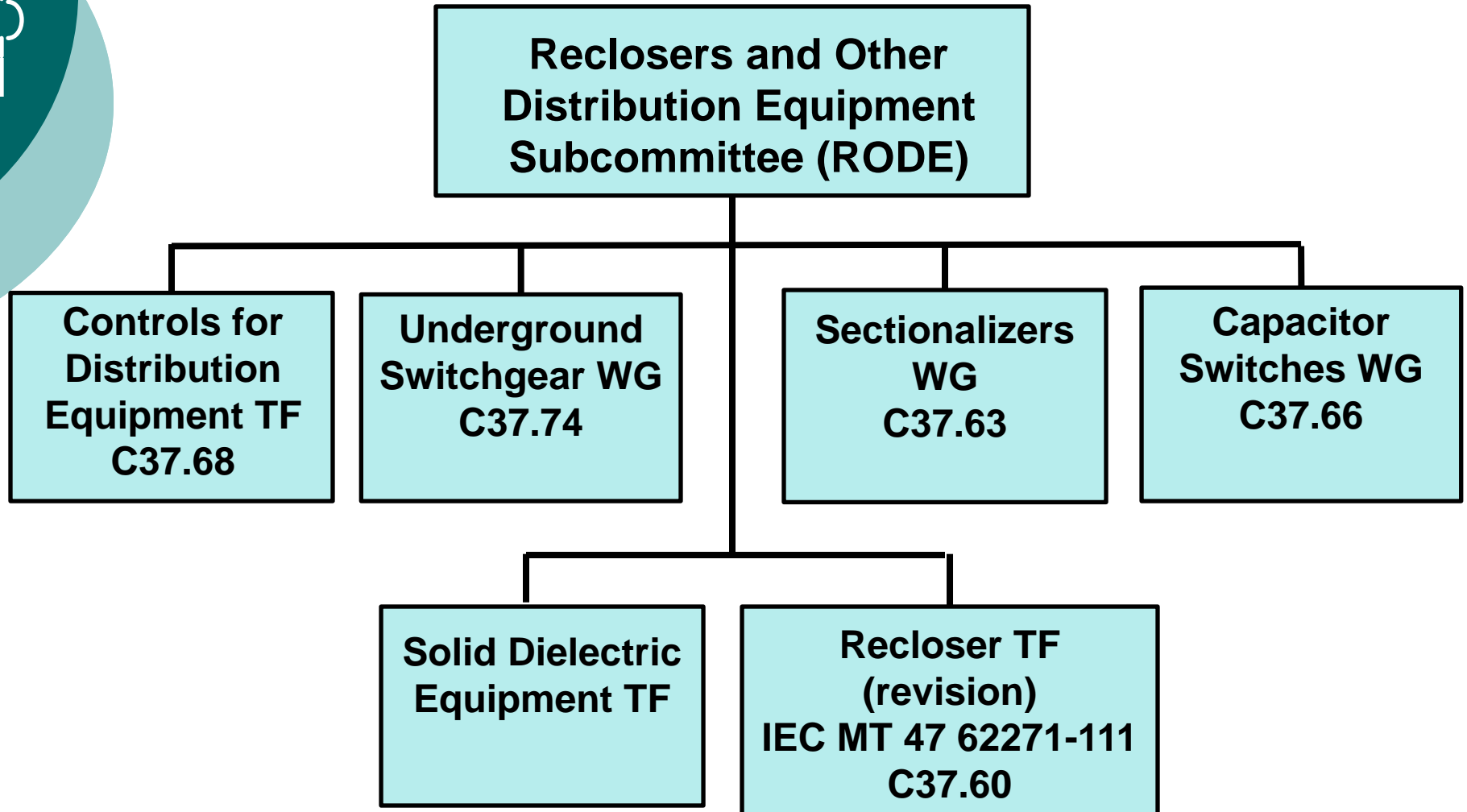

Organization – Switchgear Committee



**Switchgear Assemblies
Subcommittee (SA)**



**MV Metal-Enclosed
Interrupter (MEI)
Switchgear C37.20.3**

**Guide for Unit
Substations
C37.121**

**LV DC Traction
Power
Switchgear
C37.20.8**

**Switches for
ME Switchgear
C37.20.4**

**Guide for Testing
ME Switchgear
for Internal
Arcing Faults
C37.20.7**

**Metal-Enclosed
Bus C37.23**

**Metal-Clad
Switchgear
C37.20.2**

Organization – Switchgear Committee

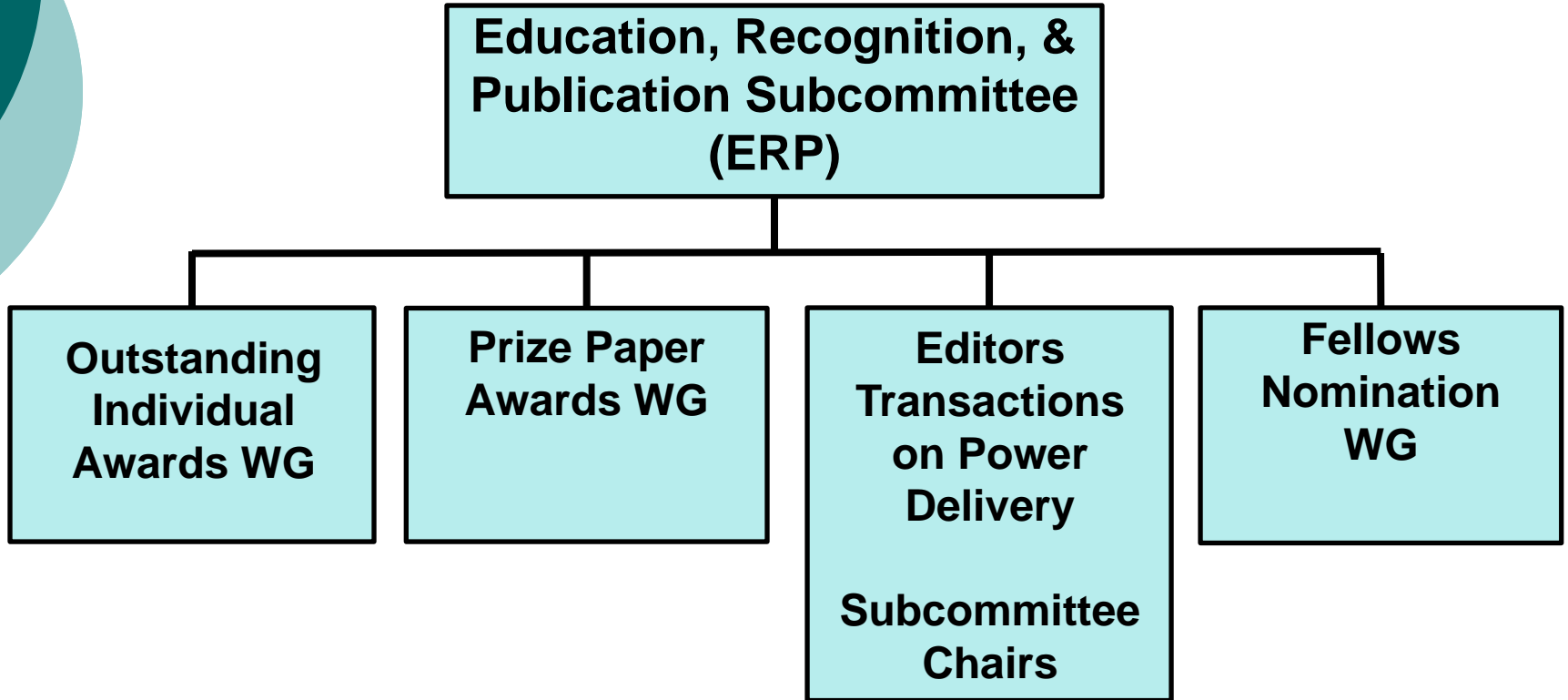



Affiliation

- Each person must state their affiliation at each meeting.
- The affiliation for each person must be recorded in the meeting minutes.
- We will provide a list in the Main Committee minutes of each attendee and the registered affiliation of that person. Only need to record deviations from that affiliation.



Frequently Asked Questions

Are Meetings Open to Everyone?

- **Generally**, meetings are **OPEN** to **all who register** for the meetings.
- **Observers** are encouraged and **welcome** to attend and participate.



Frequently Asked Questions

Are any meetings CLOSED?

- **YES.** Meetings, marked with “ * ” on the schedule, are by invitation only:
- Most **IEC**, **CIGRÉ** and **STL** meetings are restricted, and observers are welcome **ONLY** at the **pleasure of the chair**.
- Visitors are welcome at **STLNA** meetings, **but discuss your desire to attend with the chair in advance**, to be sure we have enough chairs.



Frequently Asked Questions

How do I become a member of a ballot pool?

- You do NOT have to be a member of the Switchgear Committee to review and ballot Switchgear Committee standards.
- You **DO** have to join the IEEE-Standards Association, IEEE-SA (IEEE member + \$50 for 2013)
- Create an IEEE-SA web account (no cost)
- Include the Switchgear Committee in your interest profile.
- Respond to ballot group invitations when issued, joining those ballot groups in which you have an interest.
- Joining a ballot group imposes an obligation to *participate*.



Frequently Asked Questions

How do I become a member of a Working Group or Task Force?

- Choose a subject you would like to work on
- Go to the Working Group or Task Force meetings
- Make the Working Group or Task Force Chair aware that you want to be a Working Group member
- Volunteer for an assignment (and complete it on time)
- Working Group and Task Force membership is at the discretion of the Chair for that group



Frequently Asked Questions

How do I become a member of a Subcommittee?

- Become a productive member of a Working Group or Task Force over a continuing period
- Ask the WG or TF chair to nominate you, for Subcommittee membership
- Subcommittee membership is at the discretion of the chair of that Subcommittee



Frequently Asked Questions

How do I become a member of the Main Committee?

- Be a productive member of a Subcommittee for at least two years and attend Main Committee meetings (at least four of last six).
- Be a member of IEEE Standards Association (IEEE-SA).
- Ask the Subcommittee Chair to nominate you for membership in the Main Committee.
- Main Committee membership is at the discretion of the Main Committee Chair.



Reminder

Maintain your membership

- To be a member of SG and Subcommittees you must maintain current membership in:
 - IEEE
 - Power & Energy Society (PES)
 - Standards Association (SA)
- Please make sure to update your AMS (123Signup.com) profile
<https://www.123signup.com/profile?Org=IPSC2>
- See SG Committee for more AMS (123Signup.com)
http://www.ewh.ieee.org/soc/pes/switchgear/meetings/AMS_Intro
- Please let us know of changes of status - retirement, new job, etc.



Frequently Asked Questions

Why are some standards identified as ANSI standards, some IEEE, and some IEEE/ANSI? (1 of 3)

- ANSI standards are those APPROVED by one of the processes of the American National Standards Institute.
- ANSI does NOT create standards, but accredits Standards Development Organizations [SDOs, of which there are over 270] such as IEEE, NEMA, UL, and ASTM, by approval of procedures that conform to ANSI “Essential Requirements”
- After approval in the IEEE-SA process, IEEE-SA submits approved IEEE Standards to ANSI for recognition as ANSI Standards.



Frequently Asked Questions

Why are some standards identified as ANSI standards, some IEEE, and some IEEE/ANSI? (2 of 3)

- During ANSI review, the standard is subject to public comment (comments are infrequent).
- With rare exceptions, all IEEE Switchgear Standards are recognized as ANSI standards, even if the copy available from IEEE-SA does not say so.
- ANSI audits each SDO for compliance with the Essential Requirements, usually every five years.
- NEMA, UL, ASTM, etc., and other ANSI-accredited SDOs are subject to the same rules that ANSI applies to IEEE-SA.



Frequently Asked Questions

Why are some standards identified as ANSI standards, some IEEE, and some IEEE/ANSI? (3 of 3)

- ANSI recognizes three methods:
 - organization, e.g., IEEE
 - accredited committee, e.g., ASC C37, ASC C2, etc.
 - accredited canvass, e.g., NETA.



Standards Process

- Create Project Authorization Request (PAR) and submit to IEEE-SA New Standards Committee (NesCom)
 - Requires IEEE web account
 - <http://standards.ieee.org/develop/>
 - <https://development.standards.ieee.org/my-site> - from this url, select “Access the myProject User Guide.
- Form Working Group - Create Document
- Issue Invitation to join Ballot Group to overall Ballot Pool, a subset of IEEE Standards Association [IEEE-SA]



Standards Process

- Finalize Ballot Group and initiate ballot
- After ballot, resolve ballot comments and revise draft document
- Initiate recirculation ballot and recirculate negative ballots as needed to reach a consensus
- Package final balloted draft and backup for IEEE-SA Review Committee (RevCom) & approval by IEEE Standards Board
- Publish as IEEE/ANSI Standard
- This is all managed in the IEEE myProject system



Standards Process

- IEEE-SA policy
 - No interpretations or reaffirmations
- Approved standards are valid for 10 years
- Standard must be revised within 10 years or it will be withdrawn
 - Implication - must start revision 5 years after original approval
- Balance (ANSI) - no interest category can be more than 1/3 of ballot group
 - Implication - always have at least 5 interest groups
 - myProject lists 30 interest categories - suggest selecting a reasonable number (10?) of interest groups

Interest Groups

| | | |
|--|---|--|
| Academic- researcher Academic- student Academic- teacher Academic- other Gov't – defense Gov't – regulator Gov't – other NGO – advocacy General Interest Producer – component | Producer – manufacturer Producer – Other Producer – Software Distributor (sub)Supplier Services – design Services – documentation Services – testing Services – training Services – recycle | User – consumer User - industrial User – labor User – other Consulting Insurance Research SDO Trade association Professional association |
|--|---|--|

When you initiate an invitation, you can create categories of your own, edit the “default” categories, or delete any of the 30 “default” categories. If you add a category, you must provide a brief definition/description of the category (see separate list of “default” categories along with definition/description).



Standards Process

- Access to myProject user guide
https://mentor.ieee.org/etools_documentation/dcn/11/etools_documentation-11-0014-MYPR-myproject-user-guide.pdf
- IEEE-SA myProject User Guide is an excellent reference document



Standards Process

- The Patents slides:
- You should have seen the following information when you registered for this meeting.
 - If you did not, go back into the AMS system and follow instructions from Ken Edwards on how answer these questions.
- If all registrants saw this screen, all have acknowledged the patents requirements of IEEE-SA and it is not necessary to show the Patents slides at each meeting.

t.olsen@ieee.org
Manager of Technology
Siemens Energy, Inc.
Member

Tradewinds Island Resort
5500 Gulf Boulevard
St. Pete Beach, FL
April 28 - May 3, 2012

Additional Information

Newcomer Determination

- * 1. Is this your first Switchgear Meeting attendance?

No

IEEE-SA Patent Policy

NOTE: All participants in this meeting have certain obligations under the IEEE-SA Patent Policy (See the Switchgear Committee's website for additional information, refer to the IEEE Patent Policy "section"). Participants shall inform the IEEE of the identity of each "holder of any potential Essential Patent Claims of which they are personally aware" if the claims are owned or controlled by the participant or the entity the participant is from, employed by, or otherwise represents. "Personal awareness" means that the participant "is personally aware that the holder may have a potential Essential Patent Claim" even if the participant is not personally aware of the specific patents or patent claims.

If anyone registering for this meeting is personally aware of the holder of any patent claims that are potentially essential to the implementation of any of the proposed standard(s) under consideration by any task Force, Working Group or Subcommittee that they will be participating in and that are not already the subject of an "Accepted Letter of Assurance" they are encouraged to disclose that information.

(If you answer YES you will possibly be contacted by the Switchgear Committee Secretary for additional information)

- * 2. Are you aware of any potential Essential Patent Claims? (If you answer YES you will possibly be contacted by the Switchgear Committee Secretary for additional information.)

- If you answered YES, describe patent claims in detail and as a minimum, list the WG and/or SC that are affected, the affected document, the Essential Patent Claim, the Company and/or individual patent holder)
- 3.

If you are unsure about anything you have read, please refer to the IEEE Patent Policy "section" of the Switchgear Committee's website for additional information.